



# CONTENTS



Page 27

- 3** Are Your Electronics Protected Against Lightning Strikes?
- 6** Circuit Protection Can't Be an Afterthought
- 10** How Standards Help Shape Tomorrow's Products
- 15** The Secret to Eliminating ESD Damage? Read Your Datasheet
- 18** LEDs Need Circuit Protection, Too
- 20** Circuit protection for outdoor LED lighting
- 27** On the Final Frontier: Even Robots Need Circuit Protection
- 35** A Circuit Simplification for AC Power Supply Surge Protection Devices
- 42** Blowing Things Up & Other Reasons Why I Love My Job
- 43** Littelfuse's Thane Parker Amps Up Circuit Protection
- 44** Circuit Protection Beyond the Numbers
- 47** Circuit Protection Basics Part 1: Issues and Design Solutions

ENTER TO  
**WIN**

a two-day trip to go  
behind-the-scenes  
at NASA Johnson  
Space Center

[CLICK HERE](#)

# Are Your Electronics Protected Against Lightning Strikes?

**Charles Murray,**  
Senior Technical Editor,  
*Electronics & Test*

**T**oo often, design engineers don't want to hear about lightning. Never mind that its transient voltages can fry circuit boards, crash servers, and jeopardize data. Lightning discussions are a pain.

"A lot of design engineers don't fully understand how much damage lightning can cause," Bharat Shenoy, director of technical marketing for the Electronics Business Unit at Littelfuse Inc., told Design News. "When

**Large machinery in big buildings needs to be protected from electrical surges caused by lightning. NASA's Ames Research Center uses surge suppressors on its giant wind tunnels.** (Source: NASA Ames/Tom Trower)



you bring up lightning protection, it bothers them. They say, 'I didn't plan on spending extra money for that.' "

Shenoy has a message, though, for engineers building high-reliability equipment: Critical applications need immunity against lightning strikes. "Think about Google or Facebook or any company that runs a big datacenter," he told us. "Can you imagine what happens when just one portion of their datacenter goes down?"

Indeed, 24-hour datacenters stand to lose big when lightning strikes, even if the strike point is half a mile away. "A lot of the transients will seep into areas of nearby buildings and induce surge currents on the wiring inside,"

Shenoy said. "Eventually, it travels back to the sensitive electronics. It happens all the time."

Mechanical protection, such as lightning rods, won't necessarily save the equipment. When lightning hits, it can deliver hundreds of thousands of amps of current, only a portion of which is handled by mechanical means. Even after passing through lightning rods and primary protection systems, stray currents in the building may be 3,000A and 6,000V.

To be sure, such surges may last for only a very short time—typically a few microseconds—but the period is nevertheless long enough to damage circuit boards. To protect against dam-



**Win a two-day trip —**  
Go behind the scenes at  
NASA Johnson Space Center!

**ENTER TO WIN**



age, Shenoy recommends three potential solutions, depending upon the type of application and surge.

The first—varistors—offer surge handling capabilities for applications involving high currents and high voltages. The second—polymer-based electrostatic discharge (ESD) suppressor—are targeted at sensor lines and input/output of measurement equipment. Such polymer-based devices offer low capacitance, and are therefore unlikely to distort the sensor signal that’s being monitored by the equipment. The third—silicon-based devices or arrays—offer speed. Silicon-based suppressors can clamp down almost instantaneously on surges. The trade-off, however, is that

they can’t handle the big currents and voltages of other suppression devices, such as varistors.

“These devices will see the surge currents and voltages build up, and they will conduct them away from the sensitive electronics, to ground,” Shenoy said.

Applications for such devices go beyond datacenters. They are often employed in costly test equipment and in large machines such as wind tunnels, housed in big buildings that can attract lightning.

Ironically, electronics designers often overlook the need for such protection because they are concerned with performance, Shenoy told us. “They don’t teach this to engineers in

school,” he said. “Everyone is worried about the packaging and performance of their systems, so they don’t make room for it. But if they take this into account early enough in the design cycle, they could save themselves a lot of problems later on.”

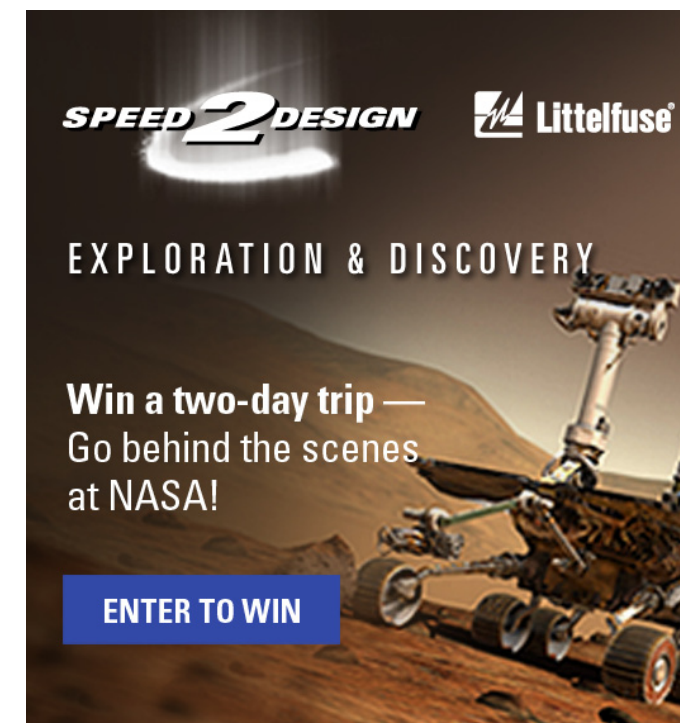

**SPEED 2 DESIGN** 

EXPLORATION & DISCOVERY

**Win a two-day trip —**  
Go behind the scenes  
at NASA!

**ENTER TO WIN**

# Circuit Protection Can't Be an Afterthought

Charles Murray, Senior Technical Editor, *Electronics & Test*

**R**unning shoes, hosiery, and nylon shirts can be death for electronic circuits. Taken together, they can generate an electrostatic discharge (ESD) of 30,000V for the briefest of moments, sending handheld devices or laptop computers into a response resembling cardiac arrest. “You walk up to a computer and bam!” Bob Capdevielle, senior applications engineer

for Littelfuse Inc., a maker of circuit protection devices, told us. “Suddenly, everything resets.”

Still, problems associated with over-voltage and over-current remain an afterthought for most engineers. With their duties expanding and with design cycles compressing, most engineers relegate circuit protection to the end of the to-do list. “These days, engineers have to design the core func-



**Polyfuse LoRho SMD Resettable PPTC Resistors provide over-current protection and automatic reset for handhelds.**

(Source: Littelfuse Inc.)

tionality of their devices as quickly as possible,” Jim Colby, manager of technology and business development for Littelfuse, said in an interview. “They have to get the form factor done, get the software done, get the prototype built, and prove out the concept. Then they have time to think about circuit protection.”

More than ever, though, that approach is creating problems for product designers. Cellphones, computers, and music players are getting smaller. Moreover, they’re running on tiny voltages that are more susceptible to ESD, distant lightning strikes, motor switching, and stray currents from process machinery. “It’s usually 10,000 or 15,000 volts,” Capdevielle

said. “But it can get really high. We’re getting calls from people asking about 30,000 volt parts.”

The unfortunate result of leaving such matters to the last minute is that design functionality suffers. Engineers can’t find room for circuit protection devices on their printed circuit boards. They end up re-spinning the boards and losing valuable development time. Worse, they hurriedly choose the wrong protection device, resulting in functional failures, poor reliability, safety issues, shock, or even fire.

For those who face the gloomy prospect of such problems, however, there’s hope. Following are the expert recommendations of engineers whose professional lives revolve around the

subjects of over-current protection and shock immunity.

**Don’t wait too long.** Colby told us:

Circuit protection can bite you if you do it too late in the project. You could put yourself in a situation where the space is not available for your ESD device. You end up settling for a non-optimal location, where the device won’t

## LV UltraMOV™ Low Voltage High Surge Varistors

### 4x Greater Surge Protection

[Learn more ▶](#)



Expertise Applied | Answers Delivered

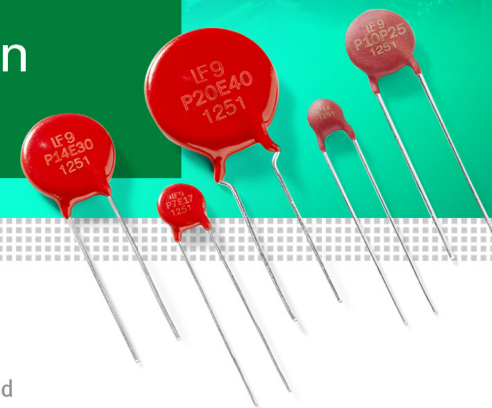

function the way it's supposed to.

The best time to start thinking about such matters is after you've picked out the chip set and begun laying out the circuit board, Colby said. Doing it in that way, ESD ratings are available and designers know how robust or how sensitive the chips are. "Some of these chips are running at 1.5 volts and you don't have to do a lot to upset them," Capdevielle said. "The circuitry is more complicated and more sensitive than we sometimes realize."

**Understand failure modes.** "Everybody understands a fuse, but over-voltage may not be so obvious, and people might not realize the consequences," Capdevielle said. The consequences, however, do exist, even if

they are not as catastrophic as those of over-current. Over-voltage has incapacitated the Hubble Telescope, shut down refineries, killed smartphones, and stopped roller coasters mid-ride. In some portable medical devices, over-voltages can even be life threatening, according to Capdevielle.

Sources of excessive current and voltage include lightning, ESD, motors, arc welders, and the aforementioned running shoes and hosiery, among others. "People understand lightning but they may not know it travels across the ground," Capdevielle said. "It can create huge glitches in power lines a mile away."

**Define the threats.** To accurately predict a product's circuit protection

needs, the design engineer must first be able to imagine how it will be used. "You have to know where the product might end up," Capdevielle said. "You have to understand its environment and what might be adjacent to it. A device will be more susceptible to a factory setting than to an office."

Once the designer understands the environment, he or she can begin making accommodations. "You should start with the connection points," Capdevielle said. "You should have an over-voltage device, not three inches away, but as close as possible to the connector."

**Be aware of standards.** Standards determine the design of every product, all the way down to the circuit protec-



**SPEED 2 DESIGN**

EXPLORATION & DISCOVERY

Win a two-day trip —  
Go behind the scenes at NASA!



ENTER TO WIN



tion. Moreover, the list of standards that designers need to be aware of is seemingly endless. “Standards are a big part of every project,” Will Li, global standards manager for Littelfuse’s Electronics Business Unit, told us. “The beginning of every product should always be to understand the standards.”

Standards pertinent to circuit protection include those from Underwriters Labs, Energy Star, NEMA, ATCA, CSA Group, IEEE, and standards bodies in Canada, South America, Japan, Korea, and Europe, among others.

Li says that designers need to be aware of standards from the outset of

every project. “It’s not as simple as coming in later and saying, ‘I’ve got this new product, so tell me about the standards,’” he said. “It doesn’t work that way.”

**Be ready to seek help.** Because circuit protection isn’t taught in universities, most engineers are more well versed in the complexities of product design than in the issues of over-current and shock immunity. That problem is compounded by the fact that most design engineers are also juggling several projects and have too little time to research the topic.

Some circuit protection manufactur-

ers provide Websites with whitepapers, product specs, and case studies. Littelfuse, for example, offers its **speed2design** site, which is geared toward helping time-challenged designers find circuit protection solutions. The company also links designers to circuit protection advice by phone.

“This is a subject that’s not taught in school, so new designers always struggle with it,” said Juan Morales, global product manager, for Littelfuse’s Electronics Business Unit. “It’s something that definitely needs to be learned through experience.”

**Figure 1.** PICO 259-UL913 Series Intrinsically Safe Fuse.



# How Standards Help Shape Tomorrow's Products

Will Li, *Littelfuse Inc.*

**C**onforming to the applicable standards for circuit protection is a critical aspect of any new electrical or electronic product's design. Ensuring those standards are incorporated into each stage of the design process is essential to moving a product from concept to certification efficiently. Occasionally, however, for some

fledgling engineering teams at startup companies, the understanding of just how to do that may come only after an unsuccessful first attempt to get their product certified. Going literally back to the drawing board or CAD system is a hard and expensive way to learn that lesson.

Design projects begin with a development specification that describes every

function and feature in the device, as well as its operating environment. Input and output signals, power conditioning, noise filtering, circuit protection, ground loops, voltage levels, qualified parts lists, cost, size, weight, and much more are all detailed in this specification. By the time a working prototype is complete, the original development spec has been replaced by a product design specification, which contains the requirements for a real, practical working product.

When the project is nearing completion and the products are in the pre-production stage, a conformance spec becomes part of the product spec. The conformance spec ensures that the product can survive its environment, perform

its intended functions, provides the level of reliability and safety the product spec requires, and meets all government, safety, and industry standards.

### From specs to standards and back again

Some companies encourage their design engineers to help develop or modify the industry standards that thread through all these specifications, supporting them in their efforts to become members of professional societies and join the technical committees and working groups that develop standards related to their products. This offers a variety of advantages to design engineers and their employers. For example, by contributing their own experience

to the development of new standards, engineers can help to ensure the safety and reliability of the next generation of products for users, operators, and maintenance people. Given that a typical committee brings together engineers from different companies that are in the same business, the committee can draw from a wider base of experience, leading to the development of standards that better reflect industry needs. Engineers who participate in standards development are also better equipped to help their companies or organizations meet the challenges new standards pose while they help keep the standards current with evolving technologies.

Littelfuse, for example, sends a representative to IEEE to ensure that the

## How Littelfuse participates in standards development

- A manufacturer's knowledge of industry standards is often a direct result of its involvement in helping to shape them. Here's a short list of some of the standards organizations with which Littelfuse is involved:
  - Canadian Standards Association (CSA) operates internationally to set standards for products and services through tests, certification, inspection for safety, and performance, including EMC and IEC testing.
  - Although CANENA is not a standards developing organization, its goal is to foster the harmonization of electrotechnical product standards, conformity assessment test requirements, and electrical codes between all democracies of the Western Hemisphere.
  - JEDEC creates standards to meet the technical and developmental needs of the microelectronics industry. Currently, a Littelfuse employee chairs the JC-22.5 Subcommittee on Transient Voltage Suppressors.
  - The Surge Protective Devices Committee of the IEEE Power and Energy Society.
  - The International Electrotechnical Commission (IEC). Littelfuse participates in standards development committees devoted to low-voltage surge protective devices (SC 37A), specific components for surge arresters and surge protective devices (SC 37B), and low-voltage fuses (SC 32B).
  - The mission of the NEMA Surge Protection Institute (NSPI) is to heighten awareness of the benefits of surge protection to all users of low voltage electrical systems in North America to promote proper application and usage.
  - UL (Underwriters Laboratories Inc.) is always looking for industry, academic, and end-user experts to help develop its consensus-based standards. Littelfuse participated in the development of several, including UL 248 (low-voltage fuses), UL 8750 (Standard for Light Emitting Diode (LED), Equipment for Use in Lighting Products), UL 60950 (Standard for Information Technology Equipment), and UL 1449 (Standard for Surge Protective Devices).

requirements for protecting circuits are uniform within the industry for a particular science (i.e., silicon solid-state circuits) and that the test procedures needed to ensure conformity are reasonable and sufficient. Engineers often also assist standards organizations such as UL, CSA, IEC, and DOE in writing test procedures that accomplish the same goals as the professional societies.

In the case of circuit protection, the process for developing a standard for the circuit protection device is largely independent of the products' use. That is, the product may be used in communication equipment, lighting, vehicles, instruments, aircraft, weapons, factory controllers, small or large appliances, or myriad other applications. Circuit

protection devices are needed for all of these applications, and the major difference among them is the magnitude and duration of a hazardous event from external sources. These events include overvoltage, overcurrent, electrostatic discharge, surge currents and voltages, and short circuits. Protection devices are essential in power and signal circuits, input-output connectors, power supplies, voltage sources, generators, motors, and circuitry of every kind.

As a standards engineer, I've helped customers understand which standards apply in terms of both the application itself and the geographical location for which it is designed, as well as offering guidance on how to meet those standards. For example, a circuit protection

product that is certified for use in a foreign country may not be acceptable for use in the US because it doesn't comply with the relevant UL safety standard.

### **UL 913 Standard helps prevent explosions in hazardous working environments**

Gases, petroleum products, and airborne dusts tend, by their very nature, to be explosive if sources of sparks or excess heat are present. UL, along with other regulatory bodies, has worked to establish and refine standards that minimize the hazards associated with these working environments. UL 913 establishes the standard for "Intrinsically Safe Apparatus and Associated Apparatus for Use in Class I, II, and III,

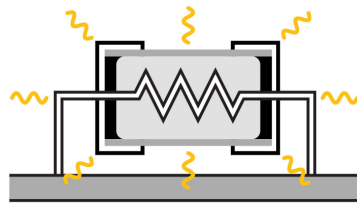

Normal Fuse  
(used in non-hazardous environments)

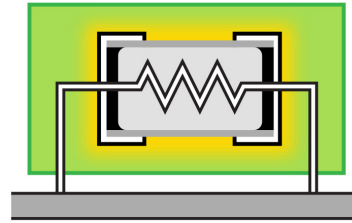

PICO 259-UL913  
Intrinsically Safe Fuse  
with Encapsulant

**Figure 2.** The encapsulant surrounding these intrinsically safe fuses keeps them sealed, limiting the energy and temperature generated during fuse operation. It also prevents dust from entering the fuse body, which makes it ideal for use in hazardous environments.

Division 1, Hazardous (Classified) Locations.” The standard specifies requirements for the construction and testing of electrical apparatus, or parts of such apparatus, having circuits that are not capable of causing ignition in Division 1 Hazardous (Classified) Locations as defined in Article 500 of the National Electrical Code, ANSI/ NFPA 70.

Various electronic devices are often used for production or maintenance activities in potentially hazardous areas, including motor controllers, lighting, communication handsets, flow meters, process control and automation, and sensors. Under normal operation,

these types of apparatus can generate tiny internal sparks from components such as motor brushes, switch contacts, and connectors. To use this type of apparatus safely in a hazardous location, the energy of such sparks must be contained to avoid igniting explosive materials in the environment. An intrinsically safe certified fuse is necessary to limit the current under any abnormal condition to ensure that the circuit will open without generating a spark capable of causing ignition. Arcing can occur when the fuse opens, which must be contained within the fuse’s encapsulation. The surface temperature

of the fuse also must be kept below the temperature that could ignite explosive gases or dust.

### Designing intrinsically safe circuits requires intrinsically safe fuses

Littelfuse recently developed the PICO 259-UL913 Series Intrinsically Safe Fuse (Figure 1), a range of encapsulated fuses approved under the UL 913 standard for Intrinsically Safe Electrical Equipment to operate in hazardous locations; currently, it’s the only fuse sold that is certified to meet this standard. This sealed fuse is ideal for applications in the oil, gas, mining,

chemical, and pharmaceutical industries because it is designed to operate within environments where there is danger of gas explosion from faulty circuits. The fuse's encapsulation (Figure 2) is >1mm thick, so the fuse can also be used in where flammable gases or vapors are present. This eliminates the need for an added conformal coating of the PCB where the fuse is placed. The fuse encapsulation limits the temperature and energy that is exposed to the hazardous gases in the environment and prevents particles from entering the fuse body. The encapsulation also limits the surface temperature of the fuse during operation, which allows it to be used in environments where flammable dust particles are a concern.

# The Secret to Eliminating ESD Damage? Read Your Datasheet

**Charles Murray, Senior Technical Editor,  
*Electronics & Test***

**T**he scourge of electronic devices — electrostatic discharge (ESD) — can be virtually eliminated by designers doing one simple task: reading their datasheets.

Experts advise to read them slowly, carefully, and all the way down to the fine print. Don't overlook a single word, they say. The

result could be the elimination of functional failure, shock, or even fire in an electronic device.

"Sometimes designers move too fast and assume they know what something means," Chad Marak, director of technical marketing for Littelfuse Inc., said in an interview. "But without reading all the way down to the fine print, they may find

## A typical IEC 61000-4-2 ESD waveform is characterized by its sub-nanosecond rise time and its short (~100 ns) duration.

(Source: Littelfuse Inc.)

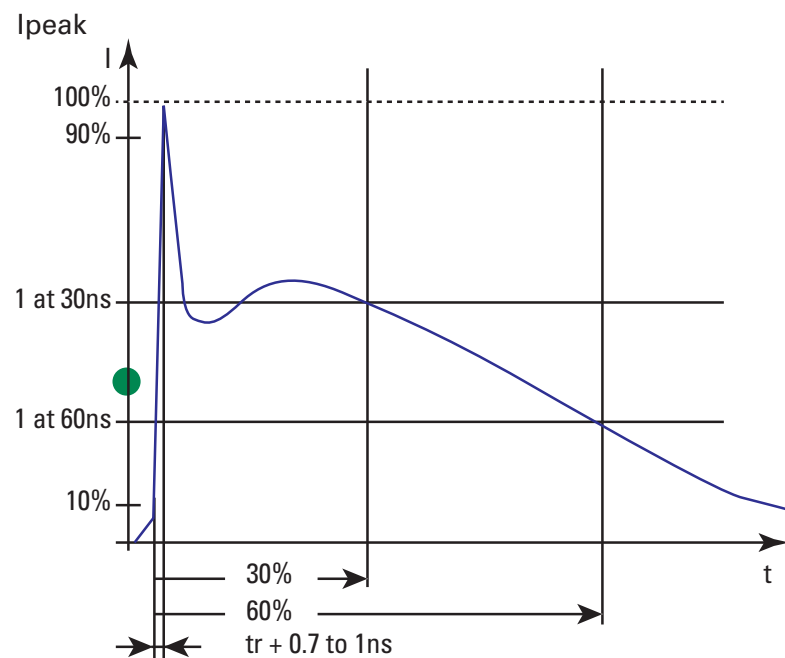

out that the information on that datasheet doesn't mean what they think it means."

Unfortunately, there's no way to quantify the relationship between careful scrutiny of a datasheet and flawless ESD performance. But it exists in devices ranging from televisions and smartphones to MP3 players and blood pressure pumps, Marak said. The trick is to know and understand the relevant specs, thus making the datasheet more understandable. Equally important, designers need to respect and understand the potential damage caused by the enormous voltages and currents that can strike an electronic device, if even for a few nanoseconds.

Marak told us:

*Walking across a carpet in winter, when the humidity level is low, and picking up a piece of electronic equipment, you can easily inject 15,000 volts. It can be about 30 amps. Most people would consider that substantial, even though it lasts for only about 100 nanoseconds, which is much less than the blink of an eye.*

Marak suggests the following for designers who are concerned about the effects of ESD:

**Read the fine print.** The ESD plot on the datasheet may not apply to your design, but you won't know that without careful scrutiny. Marak said:

*Manufacturers will inject an ESD pulse into the device they're selling, and then show a plot of it on the datasheet. But*



*if you don't read the fine print underneath that plot, you as a designer could be misled. That plot may not apply to your device.*

**Know your standards.** There are two different standards for ESD design. One, the so-called Human Body Model, applies to manufacturing environments. The other, the International Electrotechnical Commission's IEC 61000-4-2, applies to handheld devices, such as portable phones and computers. "You need to know, is the datasheet showing an IEC pulse or an HBM pulse?" Marak said. "It makes a big difference."

**Is it applicable?** Many protection device datasheets call out 2kV and 4kV pulses, even though the majority of

product manufacturers use 8kV as a benchmark. "If I'm using 8kV, then I don't care what a 2kV plot looks like," Marak said.

**Know how datasheet clamping voltages are measured.** Make sure the clamping voltages referenced in the datasheet correspond to your design. "If they're stating a clamping voltage between pins one and two, then make sure you're connecting to the same pins in your circuit," Marak said.

**Use the right layout.** "Even if you've purchased the best circuit protection device in the world, it won't matter unless you use the proper printed circuit board layout," Marak said.

For designers, the bottom line is vigilance and experience. Experienced

designers typically are better at understanding the subtleties of datasheets, but even the best can be fooled if they don't examine the sheets closely.

Marak said:

*Manufacturers use creative marketing to present their devices in the best light. So if you don't take the time to read the datasheets and understand the ESD characteristics, then you could mislead yourself into buying a device that's not going to give you the protection you expect.*

→ [Click here to view the Speed2Design TechTalk NASA Ames videos.](#)



# LEDs Need Circuit Protection, Too

**Charles Murray,**  
Senior Technical Editor,  
*Electronics & Test*

**D**esigners of LED-based systems may be glossing over one of the most important components, leaving their products susceptible to catastrophic failures, a circuit protection manufacturer said recently. “When you’re designing LEDs, a lot of thought goes into driver efficiencies and power factors, and very little thought goes into the surge immunity

standards you have to meet,” Usha Patel, director of Latin American sales and segment marketing for Littelfuse Inc., a circuit protection manufacturer, said in a recent interview. “Circuit protection is like the lost stepchild. But if you do it wrong, it can kill your entire application.”

Ironically, insufficient circuit protection may compromise the very reason for using light-emitting diodes (LEDs)



in the first place. Many engineers specify LEDs because they offer long life and low maintenance. But both of those advantages are lost if designers fail to specify the correct protection against over-current and over-voltage

situations. “LED luminaire replacements are two to three times the cost of incumbent technologies,” Patel told us. “So you want it to last a minimum of five years without having to service it.”

Patel breaks down circuit protection into two broad categories: over-current protection, which typically involves safety concerns; and surge immunity, or over-voltage protection, which often involves protection against lightning. “Over-voltage focuses on equipment reliability,” she said. “Over-current involves the risk of shock and fire.”

Both, however, can ruin an LED-based application. Voltage spikes from lightning or so-called “line swells” can ruin sensitive electronics downstream

from power supplies. Too often, though, designers are unaware of the standards involved, especially with relatively new technologies, such as LEDs. Patel said:

*LED lighting is a very fragmented market. There are many small companies that are trying to do the entire design, but they don't know what the standards are, or how to meet them. For many of the lighting designers, this is something new.*

To know what the surge level will be, Patel recommends that designers first consider the location of the application. Indoor applications differ from covered outdoor applications, such as parking garages, and from uncovered applications, such as streetlights. “A lot

of designers will buy the power supply, LEDs, heat sinks and thermal parts, then try to put it all together,” Patel told us. “But the driver may only be rated at 2 kV or 4 kV, whereas an outdoor application needs to meet 10 kV.”

Engineers should start considering such issues after they've picked their power supply and LED driver. That way they'll know how much current will be driven through the system and what the driver's rating will be. They can then add protection in front of the driver or as an external module. Protection is critical, not only because products can be ruined, but because unprotected systems can have safety concerns. “You need to have short-circuit protection,” Patel said. “Exces-

sive current causes heat, which leads to fire.”

To deal with over-voltage situations, Patel recommends customers thoroughly understand their LED drivers, and in some cases, use transient voltage suppression (TVS) diodes. Such solutions aren't always obvious, however, especially for those who are exploring new technical territories. Patel said:

*We are bailing out customers all day long. Their electronics are blowing, and they say, 'but we put in AC protection.' For some reason, though, they still have too much energy running through their circuits. It happens all the time.*

# Circuit protection for outdoor LED lighting

**Phillip Havens, *Littelfuse***

**L**ED lighting is fast becoming the lighting design of choice for contemporary lighting projects, both residential and commercial. Touted for its green properties, such as low maintenance costs, long life, and reduced power use, LED lighting is becoming very popular, especially in outdoor applications such as airport, highway,

and street lighting.

In the case of streetlights, LEDs are sold on the basis of low maintenance and long life. Designers, therefore, must ensure that their designs are well protected in order to realize the expected savings. However, one problem for LED lighting installations is protecting against transient over-voltage events.

Two major causes of transient overvoltage have long been recognized: system switching transients and transients triggered or excited by lightning discharges (in contrast to direct lightning discharges to the power systems, which are generally destructive and for which economical protection may be difficult to obtain). Median peak currents can range anywhere between 30 and 50 kA per strike.

Typical outdoor lighting includes not only street lighting but also parking lots and walkways. In most traditional lighting designs using sodium lamps, the inductive ballast acts as a lamp current limiter and also provides lightning protection for the lamp. In addition, high-pressure sodium and

mercury vapor lamps are inherently rugged and, therefore, there is little need for protection beyond basic fire safety.

LED lighting, on the other hand, is considerably more susceptible to overvoltage transients caused by lightning strikes for a number of reasons. For starters, LED lighting designs use SMPSs (switch-mode power supplies) whose inputs don't provide the protection afforded by the inductive ballast in traditional street-lighting circuits. Furthermore, an SMPS requires sophisticated protection. And LEDs themselves are fragile, solid-state devices. All of these factors combine for a need for additional protection for LED lighting applications.

## System components and susceptibilities

SMPSs are not typically used in outdoor settings, so there are a number of special considerations for their use in outdoor LED lighting applications. One particular area of concern is the SMPS front end. Here, the most immediate threat is overvoltage failures. In particular, their pole-mounted outdoor location makes them vulnerable to lighting-induced overvoltages and overcurrents, two of the most common failure modes at the front end of an SMPS.

The other weak point in the lighting circuit is the LED itself. LEDs are fragile, solid-state devices, essentially diodes, structured as a P-N junction that emits light when forward biased. The

main LED failure mechanisms are mechanical and thermal in nature, involving thermal cycles, thermal shock, and LEDs operating at high temperatures, causing wire bonds to age and fail. As the metal oxidizes and becomes brittle over time, the likelihood of an LED failure increases. ESD (electrostatic-discharge) events or surges induced by nearby lightning events are another common cause of LED failure.

### Typical design example

Figure 1 shows a typical LED lighting system. In any LED lighting application, there are several areas where effective circuit protection will increase reliability. Those areas include the ac portion of the circuit prior to dc rectifi-

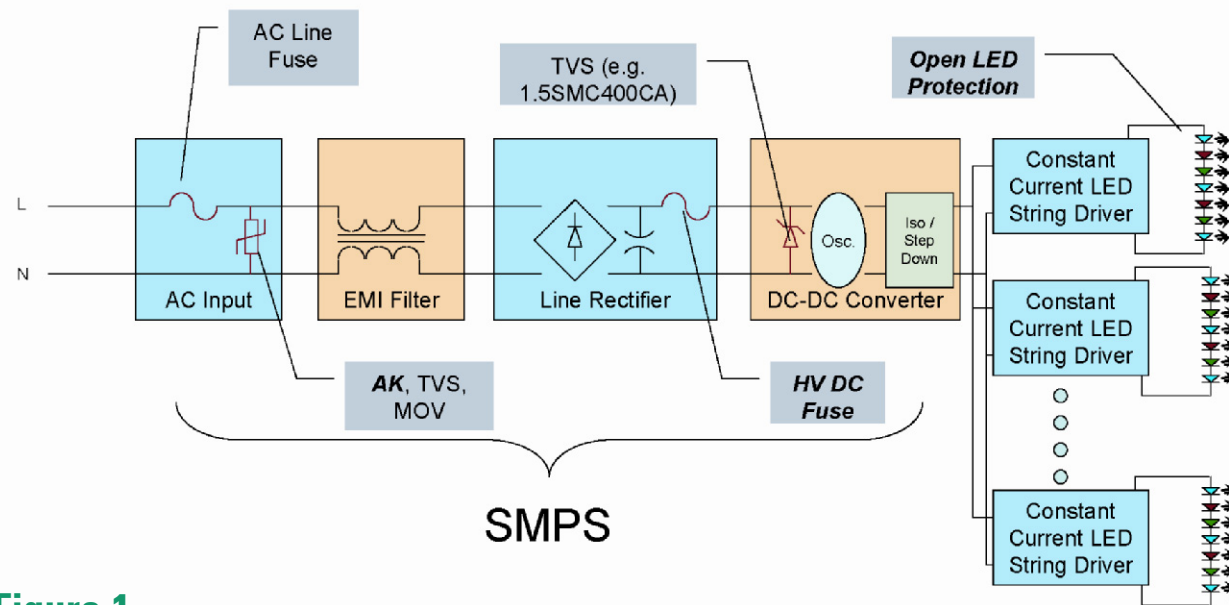

Figure 1.

cation, a dc section, and protection for the LEDs themselves.

### AC section

The first line of defense is the ac line fuse in the SMPS front end. This fuse provides basic fire protection against major system failures and must be

able to tolerate 3-kA to upwards of 6-kA surges without opening.

The first selection criterion is the voltage rating. This will depend upon the input line voltage, so 120 V-ac in North America and 220 V-ac in Europe and Asia.

Another important parameter is

what is called the breaking capacity, or  $I2t$  value, where  $I$  is the current rating of the line and  $t$  is the time in which it must open. In this case, the best fuse choice is a slow-blow or time-delay fuse in order to avoid nuisance opening.

Lastly, there is thermal derating, or re-rating. This consideration depends on knowing the ambient temperature of the environment in which the fuse will be used because fuses are sensitive to temperature. How much the fuse should be derated can be found by consulting the manufacturers' derating curves for particular device families, as these vary with voltage ratings, size, current capacity, and fuse type.

On the voltage side, there is the case

of handling overvoltage events and dealing with transient voltages. The typical protection devices for overvoltages include MOVs (metal oxide varistors) or solid-state devices.

With energy ratings from 0.1 to 10,000 joules and typical peak current ratings from 40A to 70 kA (based on standard 8x20 test waveforms), MOVs divert transient currents to ground and away from sensitive circuits. They are clamping devices, so they don't short the ac input line when they activate (doing so would trip the overcurrent protection), and they recover automatically when the overvoltage is gone. However, MOVs are metal oxide devices that degrade slightly with every successive surge activation. So while a

MOV can handle repeated large surges, each surge ages the MOV and, over time, its breakover voltage will begin to rise, reducing its effectiveness.

Silicon protectors avoid degradation, but are often rated lower (10 kA). However, solid-state devices feature better turn-on characteristics—specifically, faster switching speeds. Solid-state devices turn on at the trigger of an overvoltage event and reset at a zero crossing point. They are also generally more reliable, but also more expensive than MOVs.

Overvoltage devices have voltage-selection criteria, namely, the turn-on voltage of the device. This turn-on voltage is the voltage at which the device is activated based on an over-

voltage condition. The turn-on voltage should always be higher than the peak line voltage to avoid the device switching on intermittently.

Circuitry for power-supply protection also requires line isolation from ground to protect against possible shock hazards. These specifications are contained in IEC/UL 60950-1 and IEC/UL 6500.

**Figure 2** shows a solution that satisfies both of these requirements. The design combines MOVs with a silicon-based device. A MOV is connected between hot and neutral as well as neutral and ground, with a silicon device also between neutral and ground. This arrangement combines the high surge rating of the MOV with the non-

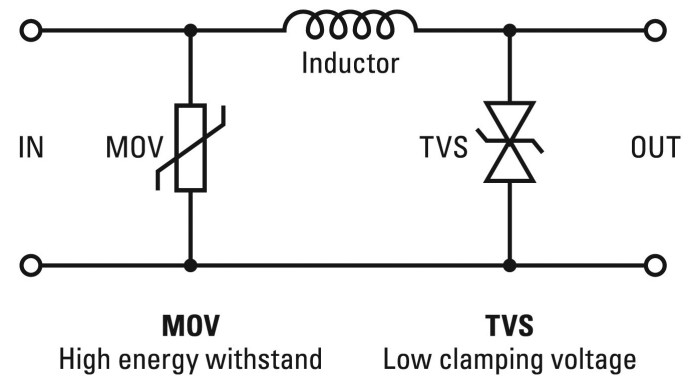

**Figure 2.**

aging reliability of the silicon device and provides protection for IEC and UL 60950 and UL 6500 requirement for line isolation from ground.

### **DC section**

The dc fuse in this section is for overcurrent protection. A fuse is placed after the voltage is rectified. The fuse provides fast protection to prevent downstream component fail-

ure, such as the dc-to-dc converter and the LED driver section. The need for a slow-blow fuse here shows up in this section. Here, voltages will typically be less than 60 V dc.

As for the ac section, the dc voltage rating for the fuse has to have a proper voltage rating for that dc line. For instance, you can't use a 15V fuse on a 30V line.

### **LED protection**

This section deals with proper circuit protection for the LEDs connected in series. **Figure 3** shows the LED section of a typical lighting application. Typical LED power ratings are between 1 and 3W. Here, we must determine the current draw from the LED watt-



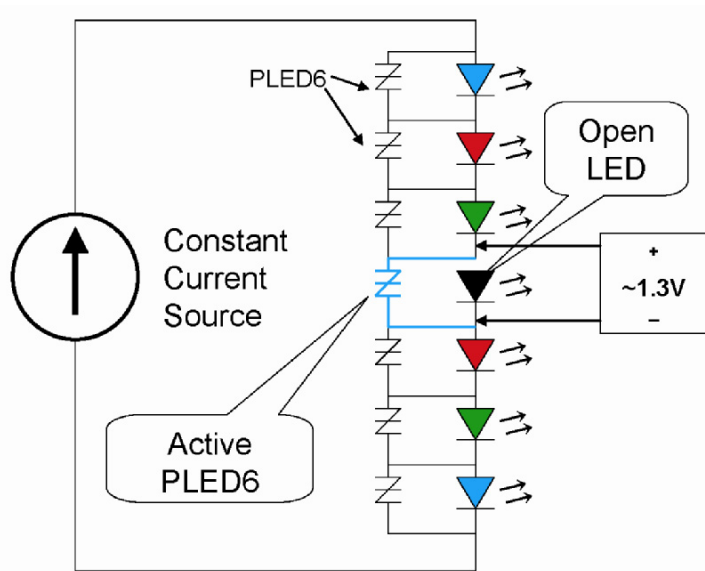

**Figure 3.**

age rating. The equation is simply  $I = P/V$ , where  $I$  is the current,  $P$  is the LED wattage rating, and  $V$  is the LED forward voltage.

LEDs are available in different wattage ratings, so these values will differ accordingly. Also, different-colored LEDs have different voltage drops.

For instance, a red LED typically has a lower forward voltage than a white LED and will therefore draw more current.

A constant current source can be used to drive the LEDs connected in series. A constant current source offers better control of LED brightness, including more uniform LED-to-LED brightness. It's important to know the compliance voltage in order to be able to select the proper open LED protection. The compliance voltage is the maximum open-circuit voltage of the constant current source.

### **Open LED protection**

Open LED protection devices provide overvoltage protection to the LED. They provide a switching elec-

tronic shunt path when a single LED in an LED array fails as an open circuit, ensuring that the entire string of series-connected LEDs will continue to function. Such devices are compatible with one-, two-, or three-watt LEDs that have a nominal 350-mA, 3V forward voltage characteristic, but can support LED applications up to 1000 mA.

Employing open LED protection is fairly straightforward. Typically, a protection device is placed in parallel with each LED in a string. A single LED failing by opening in a string of LEDs can cause a partial or full loss of the entire string. Open LED protection provides a shunt current bypass around the open LED, thus saving the LED string from partial or complete failure.

Properly selecting an open LED protector requires that the compliance voltage is known. This is the open-circuit voltage of the constant current source. When an LED fails, the compliance voltage will appear as a voltage drop across the failed LED. So when placing an open LED protector in parallel with the LED, the compliance voltage must be high enough to turn on the LED protector device. The wattage rating of the LED helps determine the steady-state voltage drop across the LED and is where the open LED protector should not turn on. This sets operating parameters for the device, and from here we can determine if we can place an open LED protector across one, two, or more LEDs.

Sometimes, two LEDs in series can be protected with one protection device as a way to lower costs if needed. An LED in the on-state drops approximately 0.7V, which is not sufficient to turn on the protector device. So multiple LEDs can be protected with a single LED protector device since the voltage drops together still do not add up to the minimum voltage needed to turn on the single LED protector device.

With wide operating temperature ranges, from -40 to +150°C, open LED protection can be used in extreme environments, often with minimal derating. Recall that one of the biggest concerns in LED operation is thermal conditions. Open LED protection devices usually have low on-state voltage, typically

1.5V, and a low off-state current. Therefore, when the overvoltage protection device turns on, it has very low thermal characteristics. So once the protection turns on, no so-called hot spots are created nearby, thus avoiding thermal-related damage to adjacent LEDs.

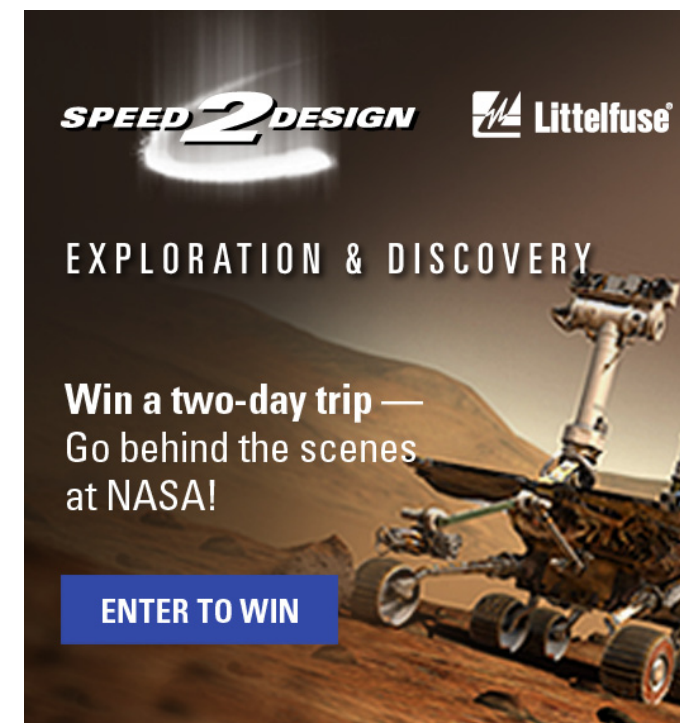

**SPEED 2 DESIGN** **Littelfuse**

EXPLORATION & DISCOVERY

**Win a two-day trip —**  
Go behind the scenes  
at NASA!

**ENTER TO WIN**

# On the **FINAL FRONTIER,** Even Robots Need Circuit Protection

*Littelfuse, Inc.*

In the 1979 film *Alien*, we were warned that “in space no one can hear you scream,” to which engineers at Littelfuse, Inc. might add, “especially when you get zapped by static.” The **Speed-2Design™** program is one way that Littelfuse is striving to minimize the consequences of unexpected jolts. And it’s not just astronauts who need protection from electrical hazards on the International Space



**It's not just astronauts who need protection from electrical hazards on the International Space Station (ISS) and other outposts on the final frontier. (Image source: NASA)**



**Littelfuse circuit protection devices, from fuses to TVS diode arrays, are as diverse as the applications they are designed to protect both on Earth and in space.**

Station (ISS) and other outposts on the final frontier. The equipment that keeps humans alive and healthy on ISS and the robotic systems that will be used to explore Mars and even more distant bodies also demand comprehensive circuit protection.

Although static shocks might typically be little more than a wintertime annoyance to humans on earth, these discharges can spell real trouble for critical electronics in orbit or on extra-terrestrial missions. For example, the soil on Mars is so dry that a robot or an astronaut could easily pick up an electrostatic charge that, when discharged, could disrupt mission-critical circuitry.

This phenomenon, known as triboelectric charging, occurs when certain

dissimilar materials rub together (like Martian soil and the various materials used in spacesuits and spacecraft such as aluminized mylar, neoprene-coated nylon, Dacron, urethane-coated nylon, tricot, and stainless steel). One material gives up some of its electrons to the other, and the separation of charge can create a strong electric field. When astronauts walk or rovers roll across the ground, their boots or wheels gather electrons as they rub through the soil. The soil is highly insulating, providing no path to ground, which can allow a space suit or rover to build up tremendous triboelectric charge. A simple touch could produce a discharge that would interfere with the operation of sensitive electrical or electronic ele-

ments and logic circuits.

Since Littelfuse was founded in 1927, the company's engineers have been designing innovative circuit protection solutions for use on earth; in the 1960s, Littelfuse first developed sub-miniature fuses that went on to be used as mission-critical components of the NASA space program.

That commitment to space-worthy innovation continues today, with the Exploration & Discovery Experience for the engineering community included as part of the Littelfuse 2013 **Speed2Design** promotion. Winning design engineers will get an opportunity to go behind the scenes to spend time with NASA engineers at Ames Research Center in Moffett Field, Calif., on August

15 and Johnson Space Center in Houston, Texas, on October 24. Winners will get a chance to talk with mission and equipment designers about the challenges of circuit protection in space, the "final frontier" of electronic circuit design.

### "Astronomical" time-to-market pressures

In 2013, the overall goal of the **Speed2Design** program continues to be to provide support and solutions for time-pressured electronic engineers seeking answers and information about proper circuit protection technology, selection, and best practices in design. A recent electronics industry survey revealed that today's engineers

are experiencing greater time-to-market pressure than ever before as new product design cycles continue to shrink. In fact, they're down 13 percent over just the past three years. Thane Parker, director of North American OEM sales for Littelfuse, explains, "Design engineers are being challenged today to get their product correct the first time and release it to market at a speed that's never been seen before. And that's what Littelfuse can bring to the table. We have the expertise that we can give the customer the answers at the speed that they need. And that's what **Speed2Design** is all about."

Littelfuse created the 2013 **Speed2Design** Exploration & Discovery experience to bring engineers face-to-face

with some of the most impressive technology on the planet. The design engineers we work with appreciate the technology challenges, demands and reliability required of the electronics that go into modern spacecraft and support systems. This year's **Speed-2Design** events offer design engineers an opportunity to get an 'up close and personal' look at the world's most advanced technologies and to talk to space exploration experts who create these innovations.

Already this year, Littelfuse has touched base with space technology experts from NASA Ames, who offered insights into some of the challenges NASA is preparing to face with new programs under development for

use on the International Space Station and in the exploration of Mars. These engineers are currently working on technological breakthroughs in small spacecraft, intelligent robotics, 3D printing, bioengineering and the NASA Space Portal.

### Safe circuitry for hazardous environments

Whether on earth or "out of this

**PICA-X heat shield protects spacecraft re-entering Earth's atmosphere at 15,660 MPH.** (Artist's rendition. Image source: NASA)



world," certain environments pose special safety requirements for circuit designs. Bharat Shenoy, director of technical marketing, Electronics Business Unit at Littelfuse, notes, "From my perspective, I see the biggest safety challenges in hazardous work zones, like those you'll find in petrochemical plants, oil/gas refineries, mines, fertilizer plants, even large-scale bakeries and cosmetics manufacturing. Equipment

designers must be vigilant about circuit protection wherever there are volatile gases, liquids, or combustible dust present in the atmosphere. By their very nature, these substances tend to be explosive if sources of sparks or excess heat are present. That's why we developed the PICO® 259-UL913 Intrinsically Safe Fuse, which is designed to operate safely within environments where there is danger of explosion from faulty circuits. It's encapsulated, which means it can be used in areas where flammable gases or vapors are present. The encapsulation eliminates the need for an added conformal coating of the circuit board where the fuse is placed and prevents particles from entering the fuse body. The encapsulation also limits the

surface temperature of the fuse during operation, so it can be used where flammable dust particles are a concern."

Being aware of safety in environments where high levels of moisture or humidity are present is important, especially those that also have a corrosive agent, such as in marine applications. These circuits usually require Ingress Protection (IP) to protect them from corrosion and shorts. Another safety concern is limiting access to circuits in order to prevent someone from being shocked or to prevent arcing to other materials. Special insulation or placement is necessary to prevent these hazards.

Recent discussions conducted with NASA engineers as part of the **Speed-**

**2Design** program offered important reminders that space holds even greater hazardous potential than earth for electronics. Dan Rasky, director and co-founder of NASA's Space Portal, is recognized as an expert on advanced entry systems and thermal protection materials, including SIRCA (Silicone Impregnated Reusable Ceramic Ablator). This close technological "cousin" of the original PICA (Phenolic Impregnated Carbon Ablator) material, has been used as part of the thermal protection system for the Mars Exploration Rover to protect components like the parachute, payload, rover, and various electronics, from the extreme heating caused by deceleration into Mars' atmosphere during the entry phase of the mission. Rasky notes,

“SIRCA is essentially a silica-based tile impregnated with silicone. It’s ideal for use in thermal protection in electronics applications like antennas because it’s both RF transparent and non-conductive.”

### Now that’s a long-distance call

Many people tend to think of technological transfer between the space program and industry as going all one way, with industry adapting technologies developed for spaceflight to earth-bound applications. But, sometimes, the opposite is true, as in the nano-satellite program funded by NASA’s Small Spacecraft Technology Program. The program, which won Popular Science magazine’s 2012 “Best of What’s New” Award for innovation in aerospace, demonstrated the ability to launch one of the least expensive,

easiest-to-build satellites ever flown in space by using off-the-shelf consumer smartphones.

NASA engineers kept the total cost of the components to build each prototype satellite to just a few thousand dollars by using only commercial hardware and establishing minimum design and mission objectives for the first flights. Out-of-the-box smartphones offer many of the capabilities satellites need, including a highly capable operating system, gyroscopes, fast processors, multiple miniature sensors, high-resolution cameras, GPS receivers, and several radios. They also offer the advantage of built-in circuit protection. The first prototype nano-satellites were 4-inch cubes that weighed just three pounds.

Chad Frost, chief of the Mission Design Division at NASA Ames, explains, “We’re

# SPEED 2 DESIGN

## EXPLORATION & DISCOVERY

Win a two-day trip —  
Go behind the scenes at NASA!

ENTER TO WIN

 Littelfuse®





really excited about being able to leverage the global community of application developers to do exciting things on this next generation of tiny spacecraft. They're an ideal platform for demonstrating and developing technology that will be applicable to bigger spacecraft. We've already shown it's possible to use tiny spacecraft to do perfectly legitimate, peer-reviewed, high-end science. For example, we've been able to miniaturize a biological lab down to the size of a French baguette for a variety of biological research payloads, including spores, bacteria, etc. They can fly completely independently on their own as satellites, and deliver their data back down to the ground."

## Circuit protection safety begins at home

Back on earth, Littelfuse continues to develop technologies designed to protect both human life and sensitive electronics. "Silicon overvoltage protection devices like the SP3304NUTG Lightning Surge TVS Diode Array and the AK Series TVS Diode protect life by maintaining the reliability and operability of equipment in the field, such as telecommunications and medical devices," says Chad Marak, director of technical marketing Semiconductor Business Unit at Littelfuse. "Equipment that's installed outdoors or that people handle regularly is especially prone to failure because of the threats posed by nearby lightning

strikes and electrostatic discharge."

All too often, earth-bound circuit design engineers tend to overlook circuit protection during the early stages of product design. Failing to take the actual protection level a component can provide into account is extremely common. For example, selecting the proper fuse is crucial to achieving optimal protection. The protected circuit's damage threshold requires thorough analysis, as does the maximum overload/short circuit that can be sourced from the power supply. The fuse selected must be able to open fast enough to prevent damage to sensitive components during both high current short circuits and low-level overall faults, which can be just as damaging from a slow heating

damage standpoint. In fact, when customers choose to use fusible resistors rather than fuses, they put themselves into a dangerous scenario because fusible resistors have dangerous opening modes during low overload conditions.

In some instances, inexperienced designers are so focused on solving the circuit's main task that they forget to consider safety or regulatory standards during the layout of the board. That means the circuit has to be modified after the fact in order to meet these standards, becoming less efficient and more expensive. As designers become more experienced, they learn how to employ best practices and to consider safety regulations from the beginning.

Chad Marak explains, "The most

common mistake is simply not thinking about circuit protection early enough in the design process! This can lead to under-designed protection elements because there's not enough space left on the circuit board or not enough capacitance budget left on a data line to allow the right device to be used. Ultimately, this leads to products prone to premature failure in the field."

Fortunately, there are resources that circuit designers can turn to in order to

learn which industry safety standards are relevant for a particular application, Will Li, global standards manager at Littelfuse notes that UL should probably always be part of the process. "Circuit designers are unique in that they need to understand the standards at the component level, as well as at the system level," says Li. "This means these designers must conform to more than one industry and/or safety standards. For example, Littelfuse engineers must



**PhoneSat 1.0 during high-altitude balloon test.**

Image source: NASA Ames Research Center)

design circuit protection components that satisfy the component standards, as well as being compliant with the standards related to the end-product they're designing. It is not always easy to understand or figure out which 'end product' standard a component should comply with – for example, there's no standard out there that's specific to designing a circuit protection component for a toaster or a juicer. In these cases, our technical marketing staff will help to determine the appropriate market. From there, we can figure out the applicable standards. LED lighting, solar panel, and battery protection applications are just a few examples of the scenarios we've worked on most recently.”

# A circuit simplification for AC power supply surge protection devices

Caiwang Sheng & Xiaoqing Zhang

## 1. Introduction

The increasing use of integrated circuits in modern electronic systems has resulted in a growing awareness about lightning overvoltage hazard. The integrated circuits, especially large-scale integrated circuits, are

vulnerable to lightning overvoltage transients, since they have very low insulation strength [1].

The overvoltage transients can cause either permanent damage, or temporary malfunctions in microelectronic components and systems. Owing

to the fact that lightning surges frequently invade the electronic systems through AC power supplies [2]-[3], it is necessary to install the surge protective devices (SPDs) on the supply lines to protect the electronic equipment against lightning overvoltages.

As far as the design of SPDs is concerned, the need exists for simplifying its circuit structure in fulfillment of the prerequisite condition of protective reliability. The circuit simplification for SPDs is of benefit to lower the cost of manufacture and reduce the size of chassis. Considering that the traditional SPD that has been extensively used on single-phase AC power supply lines requires to be assembled by more protective components, a simplified

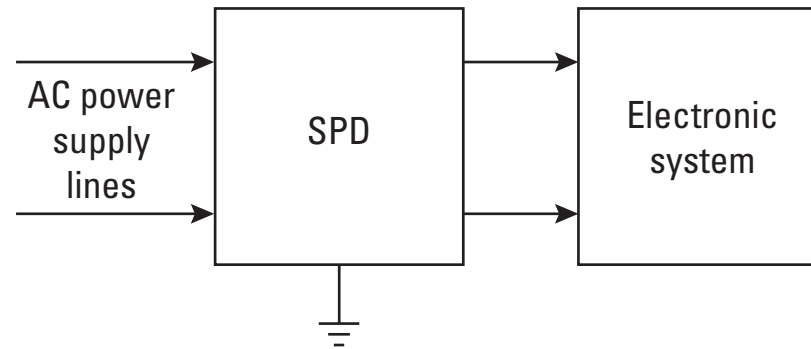

**Figure 1: SPD installed in AC power supply lines of the electronic system**

circuit is proposed in this paper for an improvement on SPD design.

Based on the simplified circuit, a significant reduction can be made in the number of the protective components. For examination of the validity of the circuit simplification, an impulse experimental arrangement is built to measure the residual voltage responses of the traditional and simplified circuit. The measured results demonstrates that the simplified circuit can be fit for the design standard [4]-[6] and have a better applicability in lightning over-

voltage protection of AC power supplies of electronic systems.

## 2. Traditional and simplified SPD circuits

The SPD under consideration is installed on the single-phase AC power supply lines to protect the electronic system against lightning overvoltage, as shown in Figure 1. According to IEC standards [5]-[6], it should include both protective modes, namely common and differential protective modes.

A traditional SPD circuit with the

both protective modes is shown in Figure 2. Metal oxide varistors M1~M6 and gas discharge tubes G1 and G2 are used in the two stages. In the first stage, M1 provides overvoltage limiting for differential mode, while M2-G1 and M3-G1 for common mode. A similar overvoltage limiting situation holds for M4, M5-G2 and M6-G2 in the second stage. L1 and L2 are decoupling inductances which are used to coordinate the protective characteristic between the two stages.

The traditional circuit shown in Figure 2 complies with the IEC standards, and is widely used on single-phase AC supply lines to protect electronic equipment from damage by lightning overvoltages. However, an obvious drawback can be seen in Figure 2. It contains more protective components and so results in a higher manufacturing cost and a larger chassis size.

In order to overcome this, a simplified SPD circuit is employed, as shown in Figure 3. In comparison with the traditional circuit, the simplified circuit reduces the number of metal oxide varistors from six to two. The SPD assembled from the simplified circuit is appreciably smaller in size than that of the traditional circuit, as shown in Figure 4.

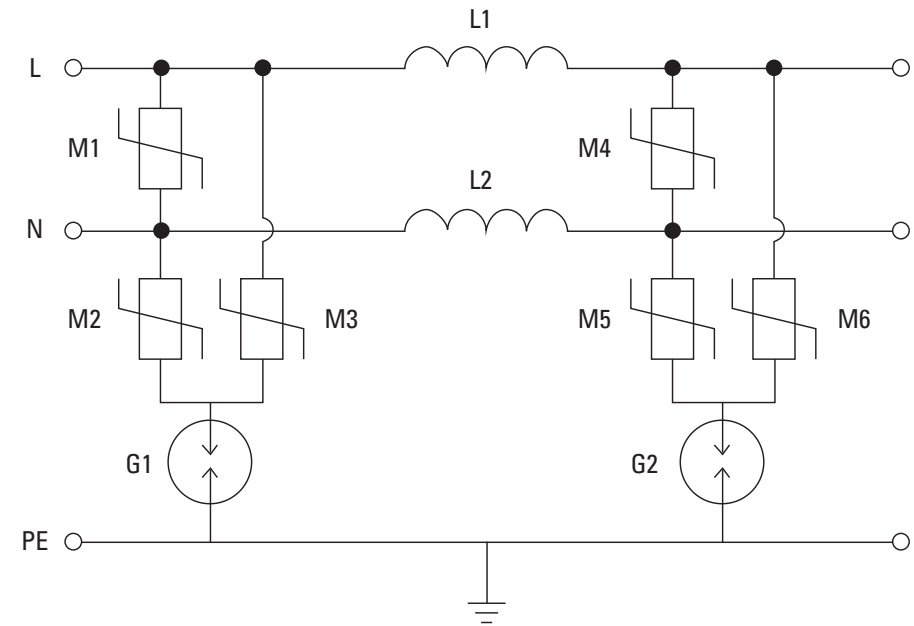

**Figure 2: Traditional SPD circuit**

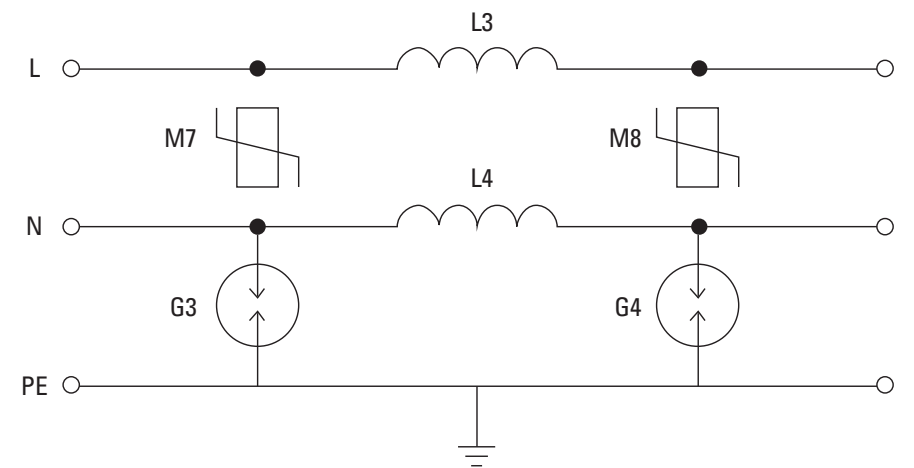

**Figure 3: Simplified SPD circuit**

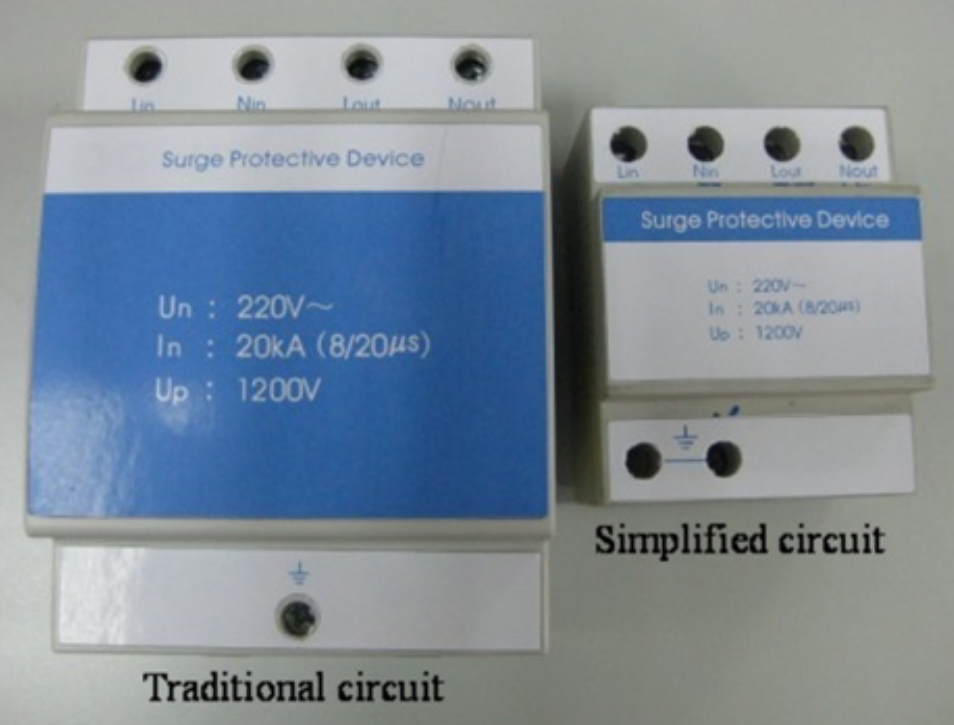

**Figure 4: Chassis sizes of traditional circuit and simplified circuit**

In the simplified circuit, the common-mode overvoltages appearing between L-PE and N-PE are limited by M7-G3, M8-G4, and G3, G4, respectively. The differential mode overvoltage appearing between L-N is limited by M7 and M8.

Considering the circuit asymmetry between L-PE and N-PE, the limitation

on the common-mode overvoltages may give rise to a differential-mode overvoltage between L-N. In such a situation, M7 and M8 can limit the resultant differential-mode overvoltage. G3 and G4 are directly connected between N-PE, so that the power frequency follow current can be prevented after the overvoltage transient is completed.

### 3. Experimental verification of protective performances

For the purpose of contrasting the protective performances of Figure 2 with that of Figure 3, experiments are made for their respective assembled SPDs. The diagram of the experimental arrangement is shown in Figure 5, where DUT denotes the assembled

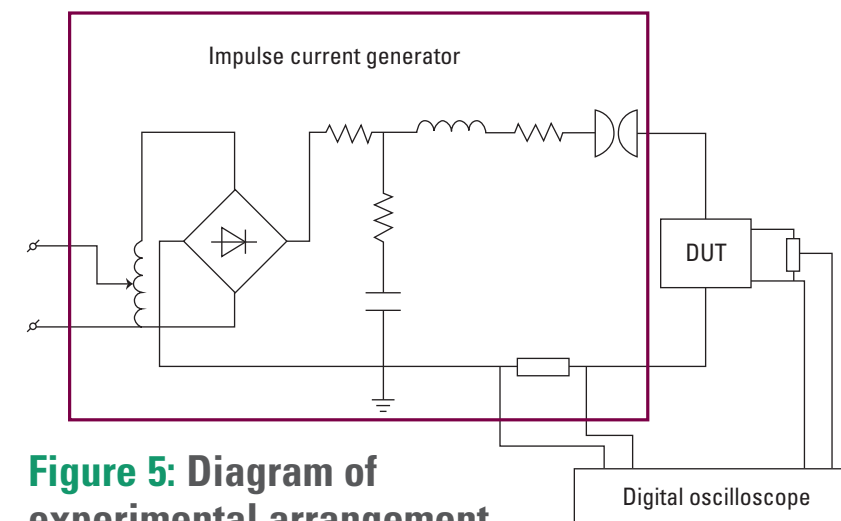

**Figure 5: Diagram of experimental arrangement**

SPD under test.

The impulse current generator, as shown in Figure 6, can generate the 8/20µs standard impulse currents. The range of its output current amplitudes is 0.3kA~40kA.

In the assembled SPDs, the varistor voltage  $V_{1mA}$  for M1, M2, M3 and M7 is taken as 621V and that for M4, M5, M6 and M8 as 511V. The nominal DC

breakover voltages VDC for G1 and G2 are 600V. The values of the decoupling inductances L1~L4 are varied from 5 $\mu$ H to 100 $\mu$ H. Such a parameter selection is suitable for protective application on the 220V AC power supply lines.

In the experiments, 8/20 $\mu$ s-20kA impulse currents are injected into the input terminals (L and N) of the assem-



**Figure 6:** 8/20 $\mu$ s impulse current generator

Decoupling inductance L1~L4 ( $\mu$ H)	Difference mode L-N (V)				Common mode L-PE (V)			
	Traditional circuit		Simplified circuit		Traditional circuit		Simplified circuit	
	Test	Simulation	Test	Simulation	Test	Simulation	Test	Simulation
5	792	820	810	840	988	1028	1015	1028
10	757	782	775	804	971	1005	979	1005
20	739	767	766	793	962	986	953	986
40	712	740	757	770	944	970	944	970
60	703	732	748	760	926	958	944	958
80	712	729	739	752	908	946	917	946
100	703	716	739	745	917	952	917	952

**Table 1:** Comparison of residual voltage peak values between traditional and simplified circuits

bled SPD respectively in differential and common modes. The residual voltages between the output terminals (L, N and PE) are measured by voltage divider and digital storage oscilloscope. The measured and simulated peak values of the residual voltages are given

in Table 1 for the assembled SPDs corresponding to Figure 2 and Figure 3.

Also, the residual voltage waveforms at inductance values of 10 and 80 $\mu$ H are shown in Figures 7-10, respectively. It can be seen from Table 1 and Figures 7-10 that the residual voltages from the

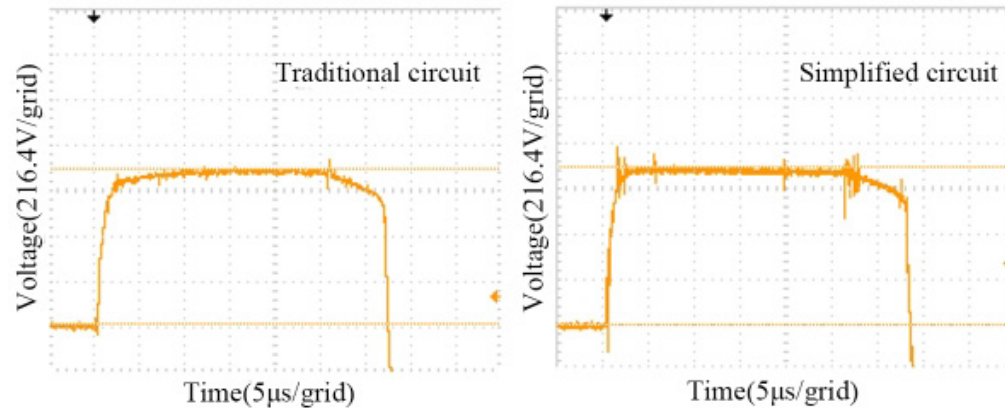

**Figure 7:** Residual differential mode voltages at inductance 10µH

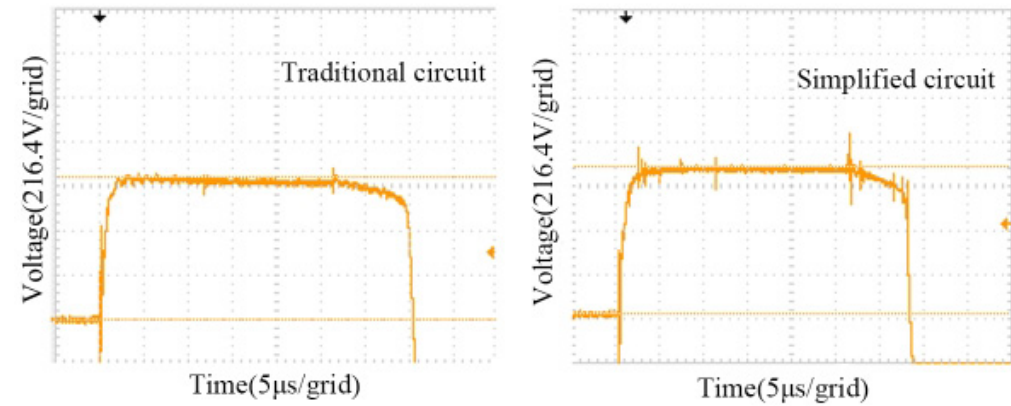

**Figure 9:** Residual differential mode voltages at inductance 80µH

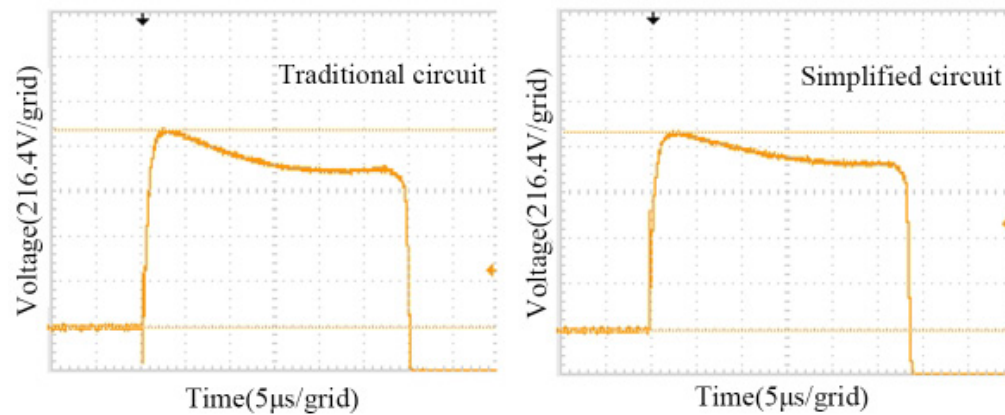

**Figure 8:** Residual common mode voltages at inductance 10µH

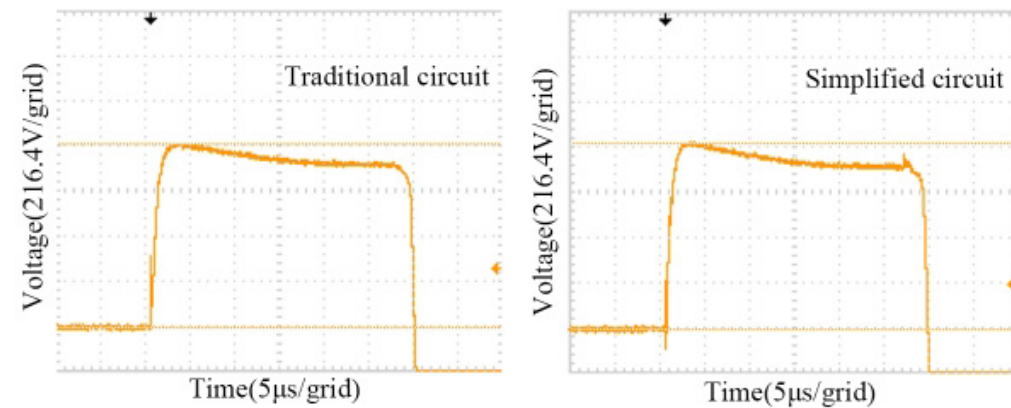

**Figure 10:** Residual common mode voltages at inductance 80µH



simplified circuit approximate those from the traditional circuit. This verifies the validity of replacing the traditional circuit by the simplified one in lightning overvoltage protection of AC power supplies.

#### 4. Conclusion

A simplified circuit has been proposed for carrying out a practical improvement in the design of the SPD installed on single-phase AC power supply lines. The experimental measurement has verified that the simplified circuit has a qualified protective performance.

The pronounced advantage of the simplified circuit over the traditional circuit is the significant reduction of

the number of protective components used in the SPD. Accordingly, the SPD assembled from the simplified circuit is smaller in size and cheaper in cost than that of the traditional circuit. This shows a better applicability of the simplified circuit in lightning overvoltage protection for AC power supplies of electronic systems.

#### References

- [1] ZHANG Xiao-qing, Lightning protection of electronic systems inside buildings, Publishing House of Electronics Industry, Beijing, China, 2000.
- [2] Peter Hasse, Overvoltage protection of low voltage systems. IEE, Power Engineering Series, No. 33, 2000
- [3] Durham, M.O. Durham, K.D. Durham, R.A., TVSS designs, IEEE Industry Applications Magazine, Vol. 8, pp. 31-36, Sep./Oct. 2002.
- [4] Chinese National Standard, GB 50057-94, Design code for protection of structure against lightning, Standard Press, Beijing, China, 2000
- [5] IEC 61643-1 Low-voltage surge protective devices – Part 1 Surge protective devices connected to low-voltage power distribution systems – Requirements and tests, 2005
- [6] IEC 61643-2 Low-voltage surge protective devices – Part 2 Surge protective devices connected to low-voltage power distribution systems -Selection and application principles, 2005

# Blowing Things Up & Other Reasons Why I Love My Job

*Design News Staff*

recently took a trip to Chicago to spend some time with engineers at Littelfuse and to delve deep into the world of circuit protection. But along the way, I found out just what it was that made Littelfuse engineers tick, and how blowing stuff up is just one of the many perks of the job.

**Check out the video →**

**VIDEO:**  
**We spent some time at Littelfuse, chatting to engineers about life, the universe and everything.**



# Littelfuse's Thane Parker amps up circuit protection

*Design News Staff*

Life ain't always easy for today's design engineers. Pressured by the ever-shorter cycle turn-arounds for new products, engineers who once had months of multiple attempts to get a design right are finding their window for test op-

portunities squeezed. But that doesn't mean they can simply cut corners.

That's why it was interesting to sit down with Littelfuse's Thane Parker recently to get his take as a salesman on how his firm tries to help engineers overcome those tight product dead-

lines without risking faulty designs, or electronics that go "bang".

Parker, sales director for the North America region, said it was vital to most of Littelfuse's clients to get answers at a lightning quick pace, which is what inspired the fuse maker's



**VIDEO:** Littelfuse's director of North America sales explains the concept and philosophy behind the firm's "Speed2Design" initiative.

whole Speed2Design campaign.

Parker said he often encouraged clients to tell him about their designs, their needs and their regulatory requirements so that Littelfuse could figure out all the options available – fast.

The best part of the job, Parker said, was “being able to take those challenges that you think, ‘Oh, jeez, this design engineer is crazy, there’s no way we can meet that requirement,’ and then watching our team succeed and excel in exceeding that customer’s expectations.”

→ **Check out the video on the previous page for more.**

# Circuit Protection Beyond the Numbers

**TJ McDermott**, Senior Project Engineer,  
*Systems Interface Inc.*

In my previous blog, we examined the numbers involved in sizing the overcurrent protection for a control transformer. With help from our Littelfuse manufacturer’s rep, we decided that a 5A KTDR fuse from Littelfuse would be satisfactory to protect a 1,500VA transformer from Allen Bradley.

We checked the time/current curves for the 5A fuse and determined that it

would handle the inrush current of the transformer. This matched the transformer manufacturer’s recommended fuse size of 5A, so we felt confident of the choice.

The manufacturer’s representative knew a time-delay fuse, not a fast-acting one, should be used in the transformer application. And yet they have exactly the same size and shape and very similar part numbers: KTDR for

Littelfuse is not alone in offering similar-looking part numbers in the class CC fuse size:

Class CC Fuse Part Numbers			
Manufacturer	High Speed	Time Delay	Dual Element
Littelfuse	KTKR	KTDR	CCMR
Cooper Bussman	KTKR	FNQR	LPCC
Mersen	ATMR	ATQR	ATDR

the time-delay fuse and KTKR for the fast-acting one. Littelfuse also has a fuse in that particular family with a dual element—CCMR.

In doing the numbers last time, we discovered that a Littelfuse KTKR 5A fast-acting fuse would melt at 26A in 0.05 seconds, and a KTDR 5A time-delay fuse would melt at 48A in the same amount of time. We picked a

time-delay fuse for our transformer application in order to ride through the inrush; had we selected a fast-acting fuse, we would have had nuisance trips in our hypothetical machine.

What if our circuit protection needed a fast-acting fuse? What if the circuit did not have a large inrush, where a fast-acting fuse makes

sense? We'd go through the same exercise for sizing to get the proper fuse. But what happens if (when) that fast-acting fuse blows? It needs to be replaced by the same type (KTKR high speed).

Can you trust your customer to replace the fuse? If the machine is critical to its process, you can hope the customer has proper spares, or that a local supplier has them in stock. But you know what happens when the proper replacement isn't available, don't you? A customer will use anything handy if the equipment is down and needs to be running.

The production floor supervisor calls maintenance to say the equipment is down. A competent engineer

quickly diagnoses the problem: A loosened terminal screw caused the circuit to heat enough to blow the fuse. He tells maintenance to replace the fuse. Uh, oh, no more fast-acting KTKR fuses. Maintenance thinks, “We’re out of KTKR fast-acting fuses, but I’ve got a bunch of KTDR fuses in the same current rating. They’ll be fine.”

In our example, if a time-delay fuse gets put where a fast-acting fuse should be, the fuse will allow 20 more amps through before melting. Improper substitution, even though the fuses are identical in shape and current rating (and the part numbers differ by only one letter), can cause ma-

chine damage, fire, and possibly human injury.

Who becomes liable? Is this foreseeable misuse? The codes governing electrical panel safety require panel manufacturers to have fuse replacement schedules prominently placed on the panel (along with terminal screw torque requirements). The trick is following them. This is something that concerns every machinery manufacturer.

This makes me think of the Darwin Award given to the gentleman who removed himself from the gene pool without actually killing himself. OK, it was just an urban legend. But improper substitution

does happen. If we think Thurston Poole of the bullet fuse urban legend is an idiot, shouldn’t we think the same of the maintenance technician who replaces a fast-acting fuse with a time-delay one? Or should we be looking at the machinery manufacturer and the fuse manufacturer as the dummies for designing circuit protection where fast-acting and time-delay fuses can be mixed and matched interchangeably?

CC is just one class. We also have classes J, T, L, and H, to name a few — not to mention inverse time circuit breakers. The subject of circuit protection is not a simple one.

# 1ST FUSE

UL913 CERTIFIED

Sealed Fuse to Prevent Ignition in Hazardous Environments

[Learn more ▶](#)



# Circuit protection basics Part 1: Issues and design solutions

David McGirt, V.P. of Engineering,  
*Innovolt*

The use of electronic equipment in industrial, commercial and residential environments continues to grow exponentially. All require power to operate and all are significantly impacted by complex power disturbances. As a result, the inconsistency of the power grid places the reliability and efficiency of equipment in constant jeopardy.

In Part 1 of this two-part series, I will lay out the issues and the component and design solutions that you can use to resolve them. In Part 2 I will look specifically at predictive analysis: how it works and typical implementation.

## Two Core Issues

I see two major issues putting electronic equipment and the circuits at risk:

First, education and training within our industry about the engineering behind the grid and circuit protection leaves a lot to be desired. Historically, not a lot of people have studied the real problems of the power grid. The fact is, electronics have grown increasingly sophisticated, yet the grid and the outlet designs powering them are seriously antiquated. Circuit protection has advanced little, making us limited

in the ability to meet the protection requirements demanded by today's increasingly digital world.

When designing a power supply, you assume that the power coming out is going to be 120 V or 60 Hz, but never have we really explored the irregularities that are common with today's grid and its damaging affects to modern day electronics. The bottom line: our industry is working mainly within an outdated system and little is being done to research big-picture solutions, putting both devices and the aging grid at risk.

The second most significant problem related to the grid and circuit protection today is the "silent killer," otherwise known as voltage sags. Voltage

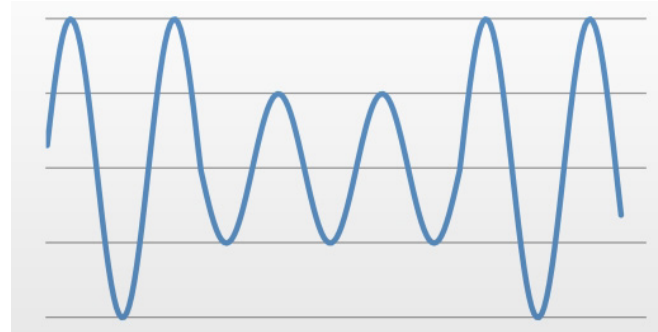

**When a voltage sag occurs, capacitors inside your equipment are discharged. When the voltage returns to normal levels, the capacitors draw in current to recharge. This current inrush can reach levels five to 10 times higher than the normal current draw, negatively affecting circuits.**

sags, which happen quite often, are a secondary effect of a very common problem, which, for the sake of this article, I'll call "The Squirrel Problem." A squirrel knocks out a line and within a one mile radius of where that fault oc-

curred everyone's power goes to zero. However, the entire grid in a 20-30 mile radius immediately begins trying to feed that one-mile fault radius to keep the power on for all affected. That action, however, drags the entire area down, reducing voltage.

Now, the fault can usually be fixed pretty quickly but within the fix lies the problem: those voltage sags create a huge current "inrush" as the voltage returns to normal, negatively affecting most pieces of electronic equipment. Today's devices pull a huge amount of current at start-up. However, the device used to limit current at start-up does not reset fast enough when a voltage sag occurs, so a huge current inrush enters unabated. The inrush far



exceeds the component ratings of the electronic device and over time that device is weakened. As a result, the device fails, experiences abnormal events and the manufacturer gains the reputation of poor quality.

The fact is that no two disturbances are the same, and the increased complexity of these disturbances in combination with one another have been proven to be catastrophic to the lifespan and reliability of electronics. It's time to recognize and fix these issues.

## Protection Choices

Before we get ahead of ourselves, let's cover the basics of circuit protection. Circuit protection refers to a variety of devices that safeguard electrical

circuits from the power disturbances. The most basic device is a fuse, a type of low resistance resistor that acts as a sacrificial device to provide over current protection, of either the load or source circuit. A fuse protects the circuit, but once it's utilized, it's kaput. The next device is a circuit breaker, which is a resettable device for stopping the flow of current in an electric circuit as a safety measure.

Over the years, technologies such as fuses and circuit breakers have led to the development of supplementary power protection devices, beginning with the surge protector and then uninterruptible power supply (UPS) technology. Unfortunately, however, the surge protection industry wasn't based

on advanced engineering; instead it used a huge marketing machine painting a picture that lightning strikes meant death to your equipment.

The reality is that less than 0.05% of power related events that damage electronics are caused by voltage surges and spikes. But the industry was selling surge devices with metal oxide varistors (MOVs) that were very unprepared for overvoltage conditions. These devices were lacking advanced engineering, started to cause fires and did not protect electronics from 99.5 percent of the disturbances in the grid. As a result of the fires, UL, a global independent safety science company, stepped in and changed protection requirements. Today if a surge protector is to be UL

certified, it must demonstrate it will not cause a fire due to overvoltage.

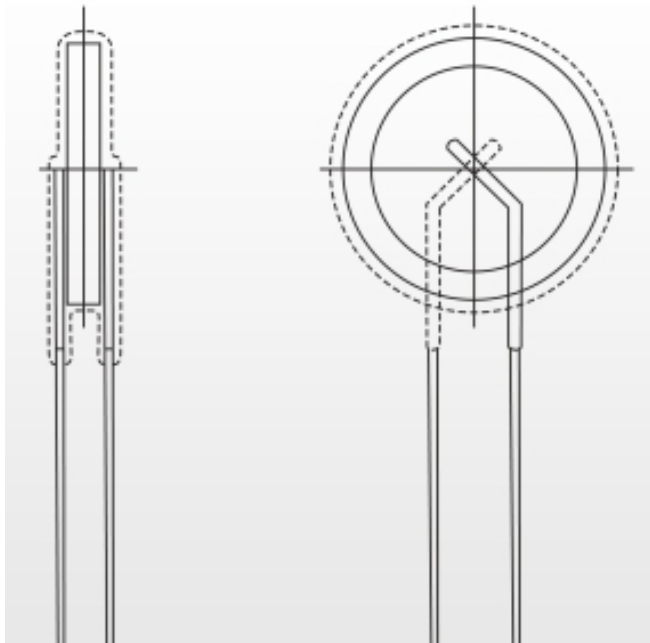

**The majority of today's protection components are limited to only protecting from voltage surges and spikes. According to I-Grid.com, less than one-half of one percent of power disturbances are caused by such disturbances, leaving today's electronics at risk.**

So what are we to do? When it comes to modern power protection, there are both external and internal solutions, each with their own pros and cons.

### **External Solutions**

The majority of today's external electronics protection choices are limited to either under-functioning surge protectors for the aftermarket consumer or unwieldy and expensive technologies, such as UPSs, for use by large enterprise systems. As I highlighted above, surge protection is an external solution designed to protect electrical devices from voltage surges and spikes.

Another more complex external solution is UPS, which provides emergency

power to a load when the input power source fails, differs from an auxiliary or emergency power system or standby generator. The main difference being that it will provide instantaneous or near-instantaneous protection from input power interruptions by means of one or more attached batteries and associated electronic circuitry for low power users, and or by means of diesel generators and flywheels for high power users.

In order to increase perceived value, surge suppressor manufacturers started including power line filters within their devices. Although line filtering is probably already inside equipment containing an SMPS, per the FCC requirement, surge suppress-

# SP3012-06UTG Low Capacitance Diode Arrays

[Learn more ▶](#)

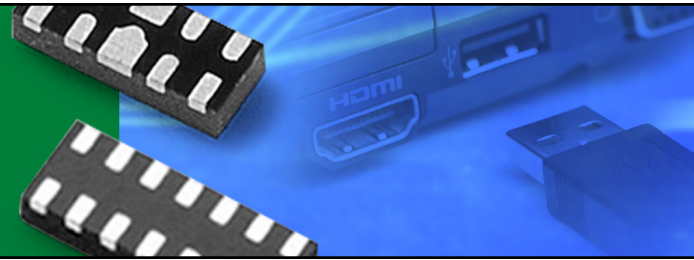

sion device manufacturers often insert additional power line filters to their products, claiming the addition enhances protection. This is misleading for a couple of reasons. First, if the line filtering is already present, the redundancy of an additional filter is unnecessary. Second, the power line filtering doesn't protect from the real killers of electronic equipment: voltage sags, over voltages, brownouts, line instability during a power outage, and last but not least, voltage surges. The filtering is an important internal component, it prevents the noise from going back to the brand circuit, but from a defense

standpoint, it simply doesn't protect.

Traditionally, UPS technology is quite effective from a technical standpoint, protecting against disturbances on the higher end by isolating electronics from the grid and powering them by battery. However, early generations of UPSs didn't do a great job of creating a real clean power outlet. Some of the early UPSs would take a square wave, which alternated regularly and instantaneously between two levels, and try and turn it into a sine, or single frequency, wave. The problem with these modified square waves, which introduced so many harmonics on the

line, is that they worked mostly on lower-range UPSs.

Today, however, the sine wave is king. The highest-quality UPSs produce a true sine wave output, which is effective but requires very expensive components in the inverter. True sine wave UPSs are normally found only in higher-end models, and the user must consider how long they can support 120 volts at a particular current level. A tiny UPS can run a cable router, but if you put your refrigerator on it, the device will probably run for 30 seconds before it runs out of juice.

What this all means is that UPSs are prohibitively expensive for most enterprise applications and too large to integrate into consumer and enterprise electronics. As a result, users either use nothing or turn to inexpensive surge protection that shields electronics from less than one percent of damaging power disturbances.

### ***Internal Solutions***

It's true we have made great strides in power supply design and internal protection technology. Modern electronic equipment utilizes switch mode power supplies (SMPS), an electronic supply that incorporates a switching regulator in order to be highly efficient in the conversion of electrical

power. Since the power supply is the link that connects a piece of electronic equipment to the grid, it might contain some type of protection elements. There are a variety of internal solutions for voltage surge suppression, but the three main choices are Metal Oxide Varistors (MOV), Transient Voltage Suppression (TVS) Diodes, or Gas Discharge Tube (GDT). Each has different characteristics that make it ideal for different applications. In general, the solutions work by shorting when its internal voltage threshold is satisfied and provides a by-pass path for surge current to discharge.

However, one thing these solutions have in common is that they do not know the difference between voltage

surges and over voltages. In other words, an over voltage can just as easily satisfy the threshold as a voltage surge can. The only difference is that the over voltage lasts much longer, which can end the usable life of some of these devices. In some cases, extended over voltages can cause the devices to burn.

### **Advances in Creating a Real Solution**

Dr. Deepak Divan of The Georgia Institute of Technology has spent the past 20 years studying the power grid. His research included studying data collected from more than 5,000 power grid sensors positioned across the North American power grid. Dr. Divan's

research shows that more than 99% of grid-based disturbances were events other than voltage surges. It turns out that voltage surges have been wrongly accused all these years.

While a voltage surge event packs an extremely destructive blow, the data shows that on average, it is not as common as believed and reported by the surge suppression community. The likelihood of receiving a voltage surge hit is less than once in 10 years on average. While the likelihood of experiencing a grid-based voltage sag: 30-100 times per year; over voltage: 1-2 times a year; brownout: 2-3 times per year; and a power outage: 2-3 times per year. Each of these events causes current inrushes upon recovery. In ad-

dition, over voltages can cause instantaneous damage. Brownouts cause erratic behavior and lockups.

Now that I've detailed the issues and the component and design solutions that you can use to resolve them, I challenge you to take some time to evaluate the basics of circuit protection. How are you protecting your products? What components and solutions are you utilizing today? As the

grid continues to age and product innovation leads to more complex devices, advances in protection technologies and effective implementation are essential. Dr. Divan's experience and research has led to the development of advanced protection technologies. In part 2, I will specifically look at new, predictive technologies that address the technical problems designers and end-users are faced with.

Over Voltages 5%

Brown Outs 10%

Power Outages 10%

Voltage Sags 74.5%

Voltage Surges/Spikes 0.5%

